

AccuSign® DOA 4

THC/OPI/COC/AMP

One-Step Panel Assay for Drugs of Abuse

For *In Vitro* Use Only

Simple One-Step Immunoassay for the Qualitative Detection of THC, Opiates, Cocaine, Amphetamine, and/or their Metabolites in Urine

Catalog No.	DOA-240-35	35 Test Kit
	DOA-240-10	10 Test Kit

Intended Use

The **AccuSign® DOA 4 THC/OPI/COC/AMP** Panel Assay is a simple, one-step immunochromatographic test for the rapid, qualitative detection of THC, opiates, cocaine, amphetamine, and/or their metabolites in human urine. The test detects the major metabolites of these drugs at the following cutoff concentrations.

THC	11-nor- Δ^9 -THC-9-carboxylic acid	50 ng/mL
OPI	Morphine	300 ng/mL
COC	Benzoyllecgonine	300 ng/mL
AMP	D-Amphetamine	1000 ng/mL

The AccuSign® DOA 4 THC/OPI/COC/AMP test provides only a preliminary analytical result. A more specific alternative chemical method must be used in order to obtain a confirmed analytical result. Gas chromatography, mass spectrometry (GC/MS) is the preferred confirmatory method. Other chemical confirmatory methods are available. Clinical consideration and professional judgment should be applied to any drug of abuse test result, particularly when preliminary positive results are used.¹

Summary and Explanation

THC (Δ^9 -tetrahydrocannabinol) is the primary active ingredient in cannabinoids (marijuana). When ingested or smoked, it produces euphoric effects. Users may experience impairment of short term memory, and THC use slows learning. Also, it may cause transient episodes of confusion, anxiety, or frank toxic delirium. Long term, relatively heavy use may be associated with behavioral disorders. The peak effect of smoking THC occurs in 20–30 minutes and the duration is 90–120 minutes after one cigarette. Elevated levels of urinary metabolites are found within hours of exposure and remain detectable for 3–10 days after smoking. Concentrations of the urinary metabolites depend on the total amount of THC absorbed, frequency of abuse, rate of release from fatty tissue, and time of sample collection with respect to use. In chronic users, THC may accumulate in fatty tissues faster than it can be eliminated. The main metabolite excreted in the urine is 11-nor- Δ^9 -tetrahydrocannabinol-9-carboxylic acid.³

Morphine, codeine, and semisynthetic derivatives of morphine belong to the class of drugs called opiates. An opiate exerts its effects on the central nervous system and can produce euphoria, respiratory depression and coma when it is abused. Morphine is the prototype compound of opiates. Morphine is excreted in the urine as morphine-3-glucuronide, unchanged morphine, and other minor metabolites. Heroin is metabolized to mor-

phine and codeine and excreted in the urine with a small amount in unchanged form. Codeine is also excreted as morphine and in the form of conjugates. Although some opiate metabolites appear in the feces, urinary excretion is the primary route of elimination.^{1,2,3}

Cocaine, derived from the leaves of the coca plant, is a potent central nervous system (CNS) stimulant and a local anesthetic. Cocaine induces euphoria, confidence and a sense of increased energy in the user; these psychological effects are accompanied by increased heart rate, dilation of the pupils, fever, tremors and sweating. Cocaine is used by smoking, intravenous, intranasal or oral administration. Cocaine base can be smoked in a form that is commonly known as “crack”, which is especially likely to lead to dependence because of its more rapid and heightened effect on the abuser. Cocaine is eliminated in the urine primarily as unchanged drug (1-9%, dependent on urine pH), benzoylecgonine (35-54%), and ecgonine (not quantified) in a 24 hour period. Benzoylecgonine has a longer biological half-life (5–8 hours) than cocaine (0.5–1.5 hours) and can generally be detected for 24–60 hours after cocaine use or exposure.^{2,4}

Amphetamine is a potent sympathomimetic agent with therapeutic applications. It is chemically related to the human body's natural catecholamines, epinephrine and norepinephrine. Acute higher doses lead to enhanced stimulation of the central nervous system and induce euphoria, alertness, reduced appetite, and a sense of increased energy and power. Cardiovascular responses to amphetamine include increased blood pressure and cardiac arrhythmias. More acute responses include anxiety, paranoia, hallucinations, and psychotic behavior. Amphetamine is largely inactivated during metabolism, being deaminated to phenylacetone which is subsequently oxidized to benzoic acid and excreted as conjugates. However, a small amount is converted by oxidation to norephedrine, and this compound and its parent are p-hydroxylated. Probably the entire dose of amphetamine is eliminated from the urine over a period of several days; normally about 30% is excreted unchanged in the 24-hour urine, but this may increase to as much as 74% in acid urine and may decrease to 1% in alkaline urine. Under normal conditions 0.9% is excreted as phenylacetone, 16-28% as hippuric acid, 4% as benzoylglucuronide, 2% as norephedrine, 0.3% as conjugated p-hydroxynorephedrine, and 2-4% as conjugated p-hydroxyamphetamine.^{2,5}

Principle

The **AccuSign® DOA 4** test uses solid-phase chromatographic membrane immunoassay technology for the qualitative, simultaneous detection of THC, opiates, cocaine, amphetamine, and/or their metabolites in human urine. The test is based on the principle of the highly specific immunochemical reactions between antigens and antibodies which are used for the analysis of specific substances in biological fluids. The test relies on the competition between the drug conjugates and the drugs which may be present in the urine sample, for binding to antibodies. In the test procedure, a sample of urine is placed in the Sample well of the device and is allowed to migrate upward. If the drug is present in the urine sample, it competes with the drug conjugate bound to the dye, for the limited antibodies immobilized on the membrane. If the level of drug or drug metabolite is above the cutoff level, the drug will saturate the antibodies, thus inhibiting the binding of the dye coated with drug conjugates to the antibodies on the membrane. This prevents the formation of a line on the membrane. Therefore, a drug-positive urine sample will not generate a line at the specific drug position in the Result window, indicating a positive result from positive drug competition. A negative urine sample will generate a line at the specific drug position in the Result window, indicating a negative result from an absence of competition with free drugs. The same principle of competition is applicable where the drug conjugate is immobilized on the membrane and the antibody is coated on the dye.

In addition to the Test line(s) that may appear in the Result window, a Control line is present to confirm the viability of the test. This Control line (validation line) should always appear if the test is conducted properly. Polyclonal sheep anti-mouse IgG antibody is immobilized on the control line. The monoclonal antibody-dye conjugates that pass the line will be captured and produce a colored line at the Control position (C). This works as a procedural control, confirming that proper sample volume was used and the reagent system at the Control line and the conjugate-color indicator worked properly. If insufficient sample volume is used, there may not be a Control line, indicating the test is invalid.

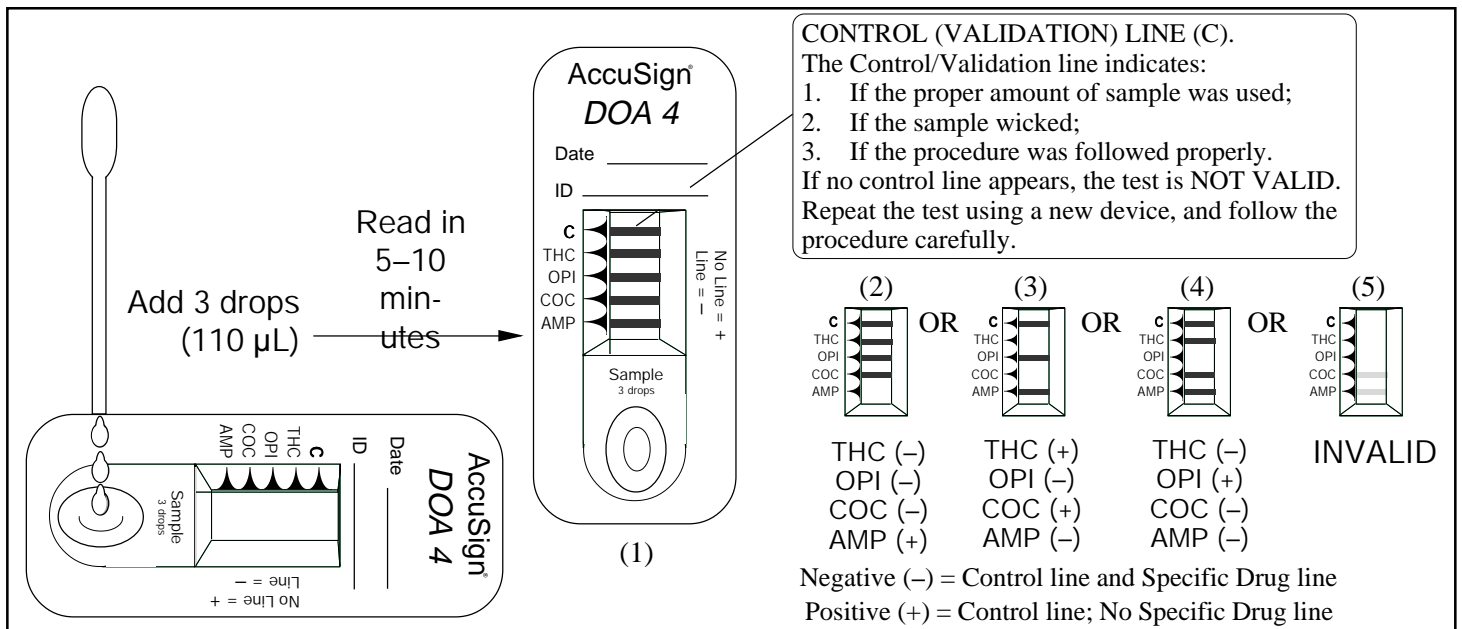

Materials Provided

AccuSign® DOA 4 test kit contains all the reagents necessary to perform the assay.

- **AccuSign® DOA 4** device. The test device contains a membrane strip and a dye pad. The membrane strip is coated with THC-protein (a purified bovine protein) conjugate, monoclonal anti-amphetamine, anti-morphine, and anti-benzoylcegonine antibodies. Sheep anti-mouse IgG antibody is coated for the control band. The dye pad contains colloidal gold coated with monoclonal anti-THC antibody, as well as conjugates of amphetamine, morphine, and benzoylcegonine (each drug is conjugated with a purified bovine protein).
- Instructions for use.
- Disposable sample dropper.

Precautions

- For *in vitro* diagnostic use only.
- Avoid cross contamination of urine samples by using a new urine specimen container and dropper for each urine sample.
- This test kit does not contain any HIV or hepatitis infective components.
- Urine specimens are potentially infectious. Proper handling and disposal methods should be followed according to good laboratory practices.
- The **AccuSign® DOA 4** device should remain in its original sealed pouch until ready for use. Do not use the test if the pouch is damaged and the seal is broken.
- Do not use the test kit after the expiration date.

Storage and Stability

The **AccuSign® DOA 4** test kit should be stored at 2–30°C (35–86°F) in the original sealed pouch. The expiration dating was established under these storage conditions.

Specimen Collection and Preparation

Approximately 110 µL of urine sample is required for each test. Fresh urine specimens do not require any special handling or pretreatment. Specimens should be collected in a clean glass or plastic container. If testing will not be performed immediately, specimens should be refrigerated (2–8°C) or frozen. Specimens should be brought to room temperature before testing.

Specimens containing a large amount of particulate matter may give inconsistent test results. These specimens should be clarified by centrifuging or allowing to settle before testing.

Test Procedure

The test procedure consists of adding the urine sample to the Sample well of the device and watching for the appearance of colored lines in the Result window.

Test Protocol

1. For each test, open one **AccuSign® DOA 4** pouch and label the **AccuSign® DOA 4** device with the patient ID.
2. Holding the dropper vertically, dispense 3 drops (110 µL) of the urine sample into the Sample well.
3. Read the result after 5 minutes, but within 10 minutes.

Interpretation of Results

Negative: The appearance of a reddish-purple Control line (C) and a line for a specific drug indicates a negative test result; i.e., no drug above the cutoff level has been detected. The color intensities of the Control line and a specific drug line may not be equal. *Any faint line at a specific drug name in the Result window, visible in 10 minutes, should be interpreted as negative. A negative test result does not indicate the absence of drug in the sample; it only indicates the sample does not contain drug above the cutoff level in qualitative terms.*

Positive: The appearance of a reddish-purple Control line and no distinct line at a specific drug name indicates the test result is positive for that drug (i.e., the specimen contains the drug at a concentration above the cutoff level). *A positive test result does not provide any indication of the level of intoxication or urinary concentration of the drug in the sample; it only indicates the sample contains drug above the cutoff level in qualitative terms.*

Invalid: A distinct Control line (C) should always appear. The test is invalid if no Control line forms at the C position. Such tests should be repeated with a new **AccuSign® DOA 4** test device.

Examples of possible results are shown in the diagram above.

- (1) **THC (-), Opiates (-), Cocaine (-), Amphetamines (-):** One Control line at the C position and one each at the **THC, OPI, COC,** and **AMP** positions.
- (2) **THC (-), Opiates (-), Cocaine (-), Amphetamines (+):** One Control line at the C position and one line each at the **THC, OPI,** and **COC** positions; no line at the **AMP** position.
- (3) **THC (+), Opiates (-), Cocaine (+), Amphetamines (-):** One Control line at the C position, one line each at the **OPI** and **AMP** positions; no lines at the **THC** and **COC** positions.
- (4) **THC (-), Opiates (+), Cocaine (-), Amphetamines (-):** One Control line at the C position and one line each at the **THC, COC,** and **AMP** positions; no line at the **OPI** position.
- (5) **Invalid:** No line at the C position.

There are other possible results, depending on the combinations of drugs present in the urine sample.

Limitations

- The test is designed for use with unadulterated urine only.
- There is a possibility that factors such as technical or procedural errors, as well as substances in the urine sample other than those listed in Table 4 below, may interfere with the test and cause erroneous results.
- Adulterants, such as bleach and/or alum, in urine specimens may produce erroneous results. If adulteration is suspected, the test should be repeated with a new sample.
- The test result read after 10 minutes may not be consistent with the original reading obtained within the 10 minute reading period. The test result must be read within 10 minutes of sample application.
- Certain medications containing opiates or opiate derivatives or amphetamines may produce a positive result. Additionally, foods or tea containing poppy products and/or coca leaves may produce a positive result.

User Quality Control

Internal Control: Each **AccuSign® DOA 4** test device has a built-in control. The Control line is an internal positive procedural control. A distinct reddish-purple Control line should appear in the Control position, if the test procedure is performed properly, an adequate sample volume is used, the sample and reagent are wicking on the membrane, and the test reagents at the control line and the conjugate-color indicator are reactive. In addition, if the test is performed correctly and the device is working properly, the background in the Result window will become clear and provide a distinct result. This may be considered an internal negative procedural control.

The positive and negative procedural controls contained in each **AccuSign® DOA 4** test device satisfy the requirements of testing a positive control and a negative control on a daily basis. If the Control line does not appear in the Control position, the test is invalid and a new test should be performed. If the problem persists, contact PBM for technical assistance.

External Control: External controls may also be used to assure that the reagents are working properly and that the assay procedure is followed correctly. It is recommended that a control be tested at regular intervals as good laboratory testing practice. For information on how to obtain controls, contact PBM's Technical Services.

Expected Values

AccuSign® DOA 4 is a qualitative assay. The amount of drugs and metabolites present in urine cannot be estimated by the assay. The assay results distinguish positive from negative samples. Positive results indicate the samples contain the specific drug above the cutoff concentration.

Performance Characteristics

The **AccuSign® DOA 4** Panel Assay detects THC, opiates, cocaine, amphetamines, and/or their metabolites at cutoff levels based on the recommendations of SAMHSA for screening of these drugs in urine. The following cutoff values are employed:

THC	11-nor- Δ^9 -THC-9-carboxylic acid	50 ng/mL
OPI	Morphine	300 ng/mL
COC	Benzoylcegonine	300 ng/mL
AMP	D-Amphetamine	1000 ng/mL

The accuracy of **AccuSign® DOA 4** was evaluated using clinical samples in comparison to a commercially available immunoassay: Syva® EMIT® II (Table 1).

Table 1. Accuracy: Comparison of AccuSign® DOA 4 with Syva® EMIT® II Assay

		Syva® EMIT® II (THC, 50 ng/mL cutoff)		
		Positive	Negative	TOTAL
AccuSign®	Positive	327	5	332
DOA 4 (THC)	Negative	13	655	668
TOTAL		340	660	1000

		Syva® EMIT® II (OPI, 300 ng/mL cutoff)		
		Positive	Negative	TOTAL
AccuSign®	Positive	249	0	249
DOA 4 (OPI)	Negative	1	716	717
TOTAL		250	716	966

Syva® EMIT® II (COC, 300 ng/mL cutoff)

		Positive	Negative	TOTAL
AccuSign®	Positive	369	3	372
DOA 4 (COC)	Negative	16	635	651
TOTAL		385	638	1023

		Syva® EMIT® II (AMP/MET, 1000 ng/mL cutoff for both)		
		Positive	Negative	TOTAL
AccuSign®	Positive	185	0	185
DOA 4 (AMP)	Negative	4	291	295
TOTAL		189	291	480

	Relative Sensitivity	Relative Specificity
THC	96.2% (327/340)	99.2% (655/660)
Opiates	99.6% (249/250)	> 99.9% (716/716)
Cocaine	95.8% (369/385)	99.5% (635/638)
Amphetamine	97.9% (185/189)	> 99.9% (291/291)

In a separate study, **AccuSign® DOA 4** was evaluated with specimens confirmed as positive by GC/MS for each drug. The results below demonstrate the excellent correlation of **AccuSign® DOA 4** with GC/MS (98% agreement). All specimens examined by GC/MS were clinical samples (Table 2).

Table 2. Accuracy: Comparison of AccuSign® DOA 4 with GC/MS Assay

		AccuSign®	GC/MS
THC	Positive	87	88
	Negative	1	0
OPI	Positive	73	74
	Negative	1	0
COC	Positive	77	78
	Negative	1	0
AMP	Positive	55	56
	Negative	1	0

Precision and Accuracy

The precision of the **AccuSign® DOA 4** Panel Assay was determined by testing serially diluted standard drug solutions. About 98% of the samples containing cocaine, opiates, or amphetamine and about 90% of the samples containing THC concentrations 25% over the cutoff level consistently showed positive results.

The study also included over 40 samples containing $\pm 25\%$ cutoff level of the drug as a challenge of cutoff precision. These results were found to be consistently in agreement with expected test results.

Distribution of Random Error:

Twenty (20) blind samples prepared by spiking various concentrations of cocaine, THC, morphine, or amphetamine were tested separately by two operators. The test results from the two operators showed complete agreement.

Reproducibility

The reproducibility of the test results of the **AccuSign® DOA 4** Panel Assay was examined at three different sites using a total of 15 blind controls, consisting of 5 negative samples, 5 moderately positive samples, and 5 strongly positive samples (i.e., a concentration 3 times the cutoff level). The results obtained at these three sites with these controls demonstrated 100% agreement with each other.

Specificity

The following table lists compounds that are detected by the **AccuSign® DOA 4** test. The specificity of the **AccuSign® DOA 4** test was determined by testing drug-negative specimens spiked with various drugs and drug metabolites. The results are expressed in terms of the concentration required to produce a positive result (Table 3).

Table 3. Specificity

Compound	Concentration (ng/mL)	% Cross-reactivity
THC		
Cannabinol	50,000	0.1
11-nor- Δ^8 -THC-9-COOH	250	20
11-nor- Δ^9 -THC-9-COOH	50	100
Δ^8 -THC	25,000	0.2
Δ^9 -THC	15,000	0.3
11-hydroxy- Δ^9 -THC	10,000	0.5
OPI		
Codeine	300	100
Hydrocodone	500	60
Hydromorphone	600	50
Levophanol	5,000	6
Meperidine	80,000	0.4
Morphine	300	100
Morphine-3- β -D-glucuronide	500	60
Nalorphine	1,000	30
Naloxane	100,000	0.3
Norcodeine	60,000	0.5
Oxycodone	20,000	1.5
Oxymorphone	60,000	0.5
Procaine HCl	100,000	0.3
Thebaine	5,000	6
COC		
Benzoyllecgonine	300	100
Cocaine HCl	>100,000	
Ecgonine HCl	50,000	0.6
AMP		
D-Amphetamine	1,000	100
D,L-Amphetamine	1,500	66.7
L-Amphetamine	60,000	1.7
Methylenedioxymphetamine	700	200
β -Phenethylamine	60,000	1.7
Phentermine	350	286
Tryptamine	50,000	2
Tyramine	70,000	1.4

The following compounds show no cross-reactivity when tested with **AccuSign® DOA 4** at a concentration of 100 μ g/mL (Table 4).

Table 4. Non Cross-Reacting Unrelated Compounds

Acetaminophen	Dextropropoxyphene	phetamine
Acetylsalicylate	Diazepam	Methpyrlyon
Aminopyrine	Diphenylhydantoin	Naproxen
Amitriptyline	Epinephrine	Norethindrone
Amobarbital	Erythromycin	Penicillin
Amoxapine	Estriol	Pentobarbital
Ampicillin	Gentisic acid	Phencyclidine
Apomorphine	Glutethimide	Phenolbutazone
Ascorbic acid	Guaiacol glycerol ether	Phenylpropanolamine
Atropine	Hydrochlorothiazide	Prednisone
Benzocaine	Imipramine	Secobarbital
Butabarbital	Lidocaine	Tetracycline
Chlordiazepoxide	Methadone	Tetrahydrozoline
Chlorpheniramine	p-OH Methamphetamine	Trifluoperazine
Chlorpromazine	Methaqualone	Tryptamine
Chloroquine	Methylenedioxymetham-	Zomepirac

References

- Hawks RL, Chiang CN, eds. *Urine Testing for Drugs of Abuse*. National Institute on Drug Abuse (NIDA), Research Monograph 73; 1986.
- Baselt RC. *Disposition of Toxic Drugs and Chemicals in Man*. 2nd Ed., Davis, CA: Biomedical Publ.; 1982.
- Tietz, Norbert W. *Textbook of Clinical Chemistry*. W.B. Saunders Company. 1986.
- Ambre J. *J. Anal. Toxicol.* 1985;9:241-5.
- Blum K. *Handbook of Abusable Drugs*. 1st ed. New York: Gardner Press, Inc.; 1984.

Symbols Key

	Manufactured by
	CE Mark
	Authorized Representative
	In Vitro Diagnostic Medical Device
	Catalog Number
	Consult Instructions for Use
	Batch Code
	"Use By" date in year-month-day format
	Temperature Limitation
	Contains sufficient for <n> tests
	Do not reuse
	Contents
	Test Device
	Transfer Pipette
	Instructions for Use
	One-step immunochromatographic Assay for the Detection of Drugs of Abuse in Urine
	Marijuana/Opiates/Cocaine/Amphetamine Test

AccuSign® is a Registered Trademark of Princeton BioMeditech Corporation.

Patent No.: 5,559,041



© 2000 PBM
 Printed in U.S.A.
 Revised Oct 2003
 P-5843-E 1013BL

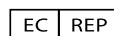

MT Promedt Consulting GmbH
 Eisenbahnstrasse 2
 D-66386 St. Ingbert
 Germany
 +49-68 94-58 10 20



Manufactured by
Princeton BioMeditech Corporation
 Princeton, NJ 08543-7139 U.S.A.
 1-732-274-1000 www.pbmc.com